

# Commercial Air Conditioners 2021/2022



**Air-cooled Screw Chiller &  
Water-cooled Flooded Screw Chiller**

# Established in 1991

TICA is a professional enterprise specialized in R&D, manufacturing, sales and services of environment cleaning and thermal energy utilization.

## Vision

Strive to be the international leading integrated system and service provider in clean environment and utilization of thermal energy

## Mission

Persist to maximize the value for customers through innovative technology and provide clean environment in order to improve the quality of life

TICA is a national high-tech enterprise, a single leading enterprise cultivated by the Ministry of Industry and Information Technology, a national brand cultivation enterprise of the Ministry of Industry and Information Technology, and a vice chairman member of China Refrigeration and Air-conditioning Industry Association. It has a national-recognized enterprise technology center, an enterprise academician workstation, and a post-doctoral research workstation. Its projects cover Beijing Bird's Nest Stadium, Water Cube, Wukesong Indoor Stadium, PetroChina, Sinopec, State Grid, Nanjing Panda, Hangzhou Xiaoshan International Airport, Hainan Airlines Group, Shangri-La Hotel, Manila Ocean Park, Abu Dhabi Al Muneera, SM City in Philippines and Unilever, etc.

TICA is also the outstanding provider of central air conditioners for China's subway networks and has successfully served nearly 70 key subway lines in major cities such as Beijing, Shanghai, Guangzhou, Shenzhen, Chengdu, Suzhou, Hangzhou and Tianjin. TICA is a professional supplier and service provider in China that specializes in system integration of clean environment. While for microelectronics, hospital operating rooms, biopharmaceutical industry and other professional purification areas, each achieving a market share of over 40%.

TICA, Visible Cleanness  
TICA, Visible Energy-Saving

## Water-cooled Flooded Screw Chiller



COOLING: 110Ton~933Ton

## Air-cooled Screw Chiller



COOLING: 110Ton~420Ton



# Contents

- ▶ Water-cooled Flooded Screw Chiller P3
- ▶ Air-cooled Screw Chiller P15

# Water-cooled Flooded Screw Chiller



TICA water-cooled flooded screw chiller adopts a compact design and is equipped with the flooded evaporator, semi-hermetic double-screw compressor and high efficient heat exchanger. Together with the advanced microcomputer control technology, the chiller is highly stable and reliable, and features efficient and quiet operations. Available in a variety of models, the units are ideal for scenarios requiring comfort and process cooling.

## Nomenclature

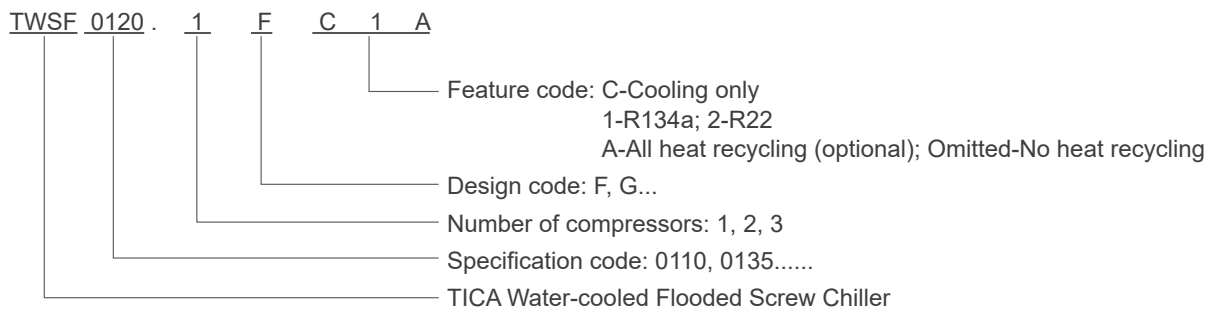

# Features



## Internationally Recognized Quality

The units have passed the certification of the Air-Conditioning, Heating and Refrigeration Institute (AHRI).

The units are up to the AHRI551/991-2011 standard (AHRI is considered to be the most prestigious organization in the international refrigeration industry).

Both TICA unit performance test bench and independently developed unit selection software have passed the AHRI certification. Every unit has to pass the test on the test bench recognized by AHRI before delivery.

TICA laboratory has obtained national CNAS certification.

## High-efficiency compressor

Efficient German compressor

- ◆ The double-screw compressor special for German patented water-cooled unit boasts high adiabatic efficiency. The high-efficiency and large-capacity motor helps significantly reduce power consumption of the unit, enabling the unit to operate efficiently in full load or partial load.
- ◆ The three-stage oil separator of the compressor works with efficiency up to 99.5%.
- ◆ With the stepless regulation of the slide valve, a single compressor can match 25%–100% load change, and a dual head unit can implement 12.5%–100% load change.
- ◆ The screw rotor is processed with patented technology, and its micron-level precision ensures precise engagement and long service life.
- ◆ The compressor motor cools down by air suction to ensure long service life, and the complete protection function guarantees safe operation of the unit.

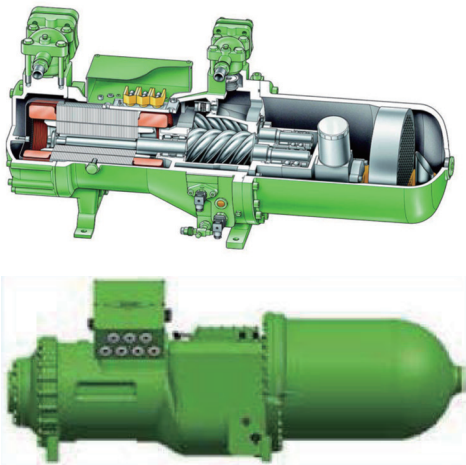

## High-efficiency heat exchanger

- ◆ The shell-and-tube type, flooded evaporator features newly arranged and enhanced bilateral heat exchange tubes to guarantee efficient heat exchange; uses CFD simulation to calculate and design liquid baffle to balance the air field, ensuring liquid level stability, and absorbing air only instead of liquid and guaranteeing stable operation.
- ◆ The shell-and-tube type condenser features built-in TICA's patented oil separator, allowing the oil separation efficiency to be up to 99.9% combined with the compressor embedded oil separator; uses CFD simulation to calculate and analyze sub-cooling part, and increases the refrigerant's supercooling degree by 2-3 times, ensuring that liquid supply pipes are free of gaseous refrigerant and the unit operates efficiently and reliably.
- ◆ The detachable lid makes it easy to cleanse the inside of heat exchange tubes, thereby ensuring high efficiency of heat exchanging.

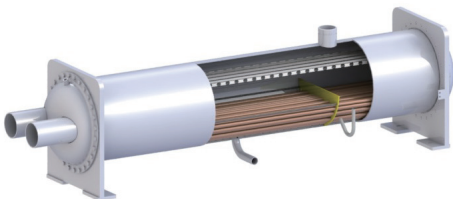

## Electronic expansion valve

- ◆ The sophisticated EXV features accurate control, fast speed of response, and a wide range of regulation, allowing the unit to operate reliably whether under full load or partial load.



## Unique oil return

- ◆ The continuous oil return technology – oil injected by oil – adopts the cutting-edge, special injection pump to inject the remaining 0.1% oil in the evaporator into the compressor to ensure safe and reliable running of the compressor.
- ◆ With TICA's patented technology of automatic oil injection, the system will automatically start oil-injection control program when the oil level in the compressor reaches the low limit, ensuring the compressor's safe and efficient operation.

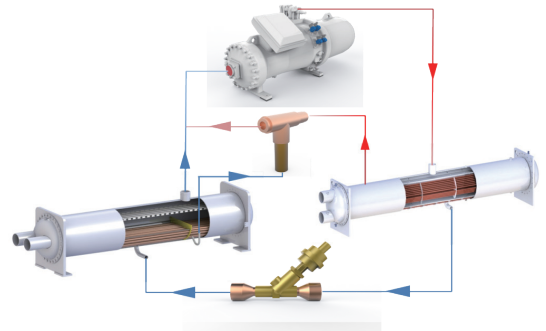

## Convenient installation

- ◆ Both the evaporator and condenser are configured with flanges and clamps to make field installation convenient.
- ◆ The unit requires a small floor area due to the compact structure.
- ◆ The refrigerant water flow ranges from 40% to 110% of the nominal flow, making it more suitable for flow variable primary pump.
- ◆ The unit is configured with a compressor startup cabinet, to facilitate on-site cable connection by the user.
- ◆ The unit is properly insulated.
- ◆ With minimal vibration, the unit is equipped with 4 pieces of 30mm chloroprene rubber shock-absorbing cushions.
- ◆ Sufficient refrigerant has been charged in the unit before the entire unit is delivered.
- ◆ During installation on site, users only need to connect the water pipes of evaporator and condenser and connect the power supply.



## Precise Control System and Reliable Operation



◆ Sophisticated control system  
—The industrial-level microcomputer controller, together with the 7-inch colored touch screen, constitutes the control unit of the unit. As a result, the unit is rather reliable and jamproof and therefore ideal for complicated, hostile working environments.

◆ Unique dynamic optimization and control algorithms  
—Benefiting from TICA's years of experience in air conditioning design and application, the control algorithms feature more precise calculation of unit load; the algorithms are integrated with TICA's unique dynamic optimization and control to allow the units to make adjustments in all operating conditions and to ensure the units are keeping running in an efficient, reliable and secure manner; The refrigerant water flow ranges from 40% to 110% of the nominal flow, making it more suitable for flow variable primary pump.

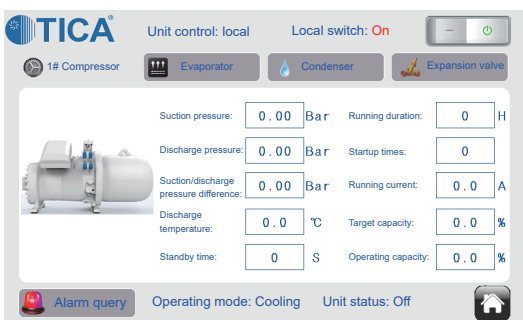

◆ Intelligent control  
—The advanced pre-control function enables measures to be taken promptly before actual failure occurs to avoid unexpected shutdown of the unit due to an alarm.

—Multiple compressors can operate automatically to reach a load balance and therefore can prolong the service life of the unit.

—Each compressor and circuit can be controlled independently and can serve as the standby for another compressor, minimizing the impact of possible faults.

—Unique oil return control technology resolves the issue of oil separation.

—Benefiting from the fuzzy control technology, the unit is able to adjust the water temperature based on outdoor air temperature and hence can enhance efficiency to the greatest extent while meeting the needs.

—The unit supports the compiling of weekly operating schedules to implement comprehensive automatic start and stop control of the unit, and can truly be left unattended.

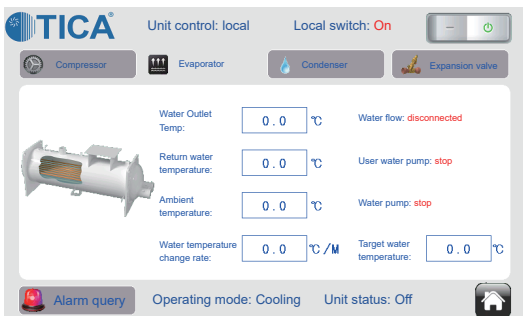

◆ Complete safety protection

—Power supply protection: phase loss, reverse phase, over-voltage, and under-voltage

—Compressor protection: protection for motor overheat, overload, frequent startup, oil level and high discharge temperature

—Pressure protection: both evaporator and condenser are equipped with safety valves, and have protection when low pressure is too low, high pressure is too high, and protection for low air suction/discharge pressure difference.

—Other protection: too low water temperature protection, too low water flow protection, sensor failure protection, etc.

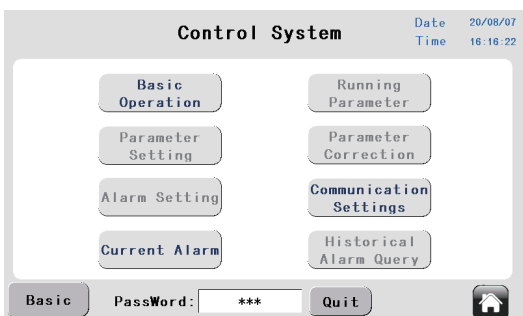

## Flexible and convenient group communication

—Standard RS485 interface and MODBUS RTU protocol are provided, and the unit is connected to the building automation system (BAS), which implements centralized control and remote monitoring of the unit and control of other attached devices according to the controlling requirement of the BAS.



# Technical Specifications

## High-efficiency series

Model		TWSF-FC1	0110.1	0135.1	0160.1	0175.1	0200.1	0220.1	0240.1	0265.1	
Capacity	Ton		110	135	156	175	200	215	235	260	
	kW		387	475	547	615	703	755	825	915	
Power input	kW		65	80	91	102	116	125	136	151	
Efficiency	kW/Ton		0.591	0.592	0.583	0.583	0.580	0.582	0.580	0.580	
COP	W/W		5.95	5.94	6.01	6.03	6.06	6.04	6.07	6.06	
Running current	A		121	141	162	176	208	215	232	260	
Starting current	A		330	415	479	506	650	650	683	845	
Compressor quantity	Set		1	1	1	1	1	1	1	1	
Power supply		380 V 3N-50 Hz									
Refrigerant		R134a									
Energy control		Stepless regulation of energy									
Evaporator	Design pressure on water side	Mpa	1.0								
	Water flow	m <sup>3</sup> /h	67	82	94	106	121	130	142	157	
	Water pressure drop	kPa	74	72	73	72	73	74	75	86	
	Piping DN	mm	150	150	150	150	150	150	150	150	
	Connection Type		victaulic coupling								
Condenser	Design pressure on water side	Mpa	1.0								
	Water flow	m <sup>3</sup> /h	78	96	110	123	141	151	165	183	
	Water pressure drop	kPa	86	77	87	86	85	72	78	68	
	Piping DN	mm	150	150	150	150	200	200	200	200	
	Connection Type		victaulic coupling								
Dimensions	Length	mm	3122	3122	3122	3122	3144	3144	3144	3144	
	Width	mm	1500	1500	1500	1500	1550	1550	1550	1550	
	Height	mm	1800	1800	1800	1800	1850	1850	1850	1850	
Shipping weight		kg	2750	3200	3250	3350	3800	3850	4000	4150	
Operating weight		kg	2950	3450	3490	3590	4150	4180	4400	4500	

★ **Note:**

1. The parameters under above operating conditions: are as follows: chilled water outlet temperature 7°C, chilled water inlet temperature 30°C.
2. For technical parameters under non-standard operating conditions, please contact TICA.
3. The maximum startup current listed in the table is the current under Y- $\Delta$  startup mode.
4. Power supply: 380V 3N-50Hz; allowable voltage fluctuation:  $\pm 10\%$ .
5. Standard water vessels pressure: 1.0 MPa.
6. Specification parameters are subject to change without prior notice, due to product improvement.

## High-efficiency series

Model	TWSF-FC1	0280.2	0300.2	0325.2	0350.2	0370.2	0390.2	0410.2	0430.2	0450.2	0465.2	0495.2	0510.2	
Capacity	Ton	277	293	316	340	367	392	409	425	441	461	486	507	
	kW	973	1030	1110	1194	1292	1379	1438	1495	1551	1620	1710	1782	
Power input	kW	161	171	184	198	215	228	238	245	255	267	281	293	
Efficiency	kW/Ton	0.582	0.584	0.583	0.583	0.585	0.581	0.582	0.576	0.578	0.579	0.578	0.578	
COP	W/W	6.04	6.02	6.03	6.03	6.01	6.05	6.04	6.10	6.08	6.07	6.09	6.08	
Running current	A	285	301	324	344	360	380	420	430	440	464	490	516	
Starting current	A	660	724	759	801	828	972	1013	1013	1048	1081	1243	1278	
Compressor quantity	Set	2	2	2	2	2	2	2	2	2	2	2	2	
Power supply	380 V 3N-50 Hz													
Refrigerant	R134a													
Energy control	Stepless regulation of energy													
Evaporator	Design pressure on water side	Mpa	1.0											
	Water flow	m <sup>3</sup> /h	167	177	191	205	222	237	247	257	267	279	294	307
	Water pressure drop	kPa	65	80	72	80	66	65	72	57	63	63	63	62
	Piping DN	mm	200	200	200	200	200	200	200	200	200	200	200	200
	Connection Type	victaulic coupling												
Condenser	Design pressure on water side	Mpa	1.0											
	Water flow	m <sup>3</sup> /h	195	207	223	240	259	276	288	300	311	325	343	357
	Water pressure drop	kPa	65	83	83	85	57	56	86	56	59	61	60	62
	Piping DN	mm	200	200	200	200	200	200	200	200	200	200	200	200
	Connection Type	victaulic coupling												
Dimensions	Length	mm	4497	4497	4497	4497	4540	4540	4540	4540	4540	4624	4624	4652
	Width	mm	1600	1600	1600	1600	1800	1800	1800	1800	1800	1800	1800	1800
	Height	mm	1950	1950	1950	1950	2050	2050	2050	2050	2050	2050	2050	2050
Shipping weight	kg	6500	6550	6650	6750	7100	7200	7250	7350	7500	7600	7750	7800	
Operating weight	kg	6970	7000	7150	7250	7800	7900	7950	8100	8250	8350	8575	8600	

★ **Note:**

1. The parameters under above operating conditions: are as follows: chilled water outlet temperature 7°C, chilled water inlet temperature 30°C.
2. For technical parameters under non-standard operating conditions, please contact branches of TICA.
3. The maximum startup current listed in the table is the current under Y- $\Delta$  startup mode.
4. Power supply: 380V 3N-50Hz; allowable voltage fluctuation:  $\pm 10\%$ .
5. Standard water vessels pressure: 1.0 MPa.
6. Specification parameters are subject to change without prior notice, due to product improvement.

## Super high-efficiency series

Model		TWSF-FC1	0430.1	0450.1	0470.1	0850.2	0900.2	0940.2
Capacity	Ton		429	450	469	854	895	933
	kW		1509	1581	1648	3002	3148	3279
Power input	kW		239	250	259	475	496	516
Efficiency	kW/Ton		0.557	0.556	0.553	0.556	0.554	0.553
COP	W/W		6.31	6.32	6.36	6.32	6.35	6.35
Running current	A		404	421	438	803	835	871
Starting current	A		1033	1033	1033	1668	1668	1668
Compressor quantity	Set		1	1	1	2	2	2
Power supply		380 V 3N-50 Hz						
Refrigerant		R134a						
Energy control		Stepless regulation of energy						
Evaporator	Design pressure on water side	Mpa	1.0					
	Water flow	m <sup>3</sup> /h	260	272	284	516	541	564
	Water pressure drop	kPa	60	45	40	60	60	70
	Piping DN	mm	200	200	200	250	250	250
	Connection Type		Virtual coupling					
Condenser	Design pressure on water side	Mpa	1.0					
	Water flow	m <sup>3</sup> /h	301	315	328	598	627	653
	Water pressure drop	kPa	40	45	40	80	80	70
	Piping DN	mm	250	250	250	300	300	300
	Connection Type		virtual coupling					
Dimensions	Length	mm	4800	4800	4800	6700	6700	6700
	Width	mm	2260	2260	2260	2700	2700	2700
	Height	mm	2600	2600	2600	2750	2750	2750
Shipping weight		kg	7800	8300	8800	13000	14000	15000
Operating weight		kg	8970	9500	10100	14950	16000	17000

★ **Note:**

1. The parameters under above operating conditions are as follows: chilled water outlet temperature 7°C, chilled water inlet temperature 30°C.
2. For technical parameters under non-standard operating conditions, please contact branches of TICA.
3. The maximum startup current listed in the table is the current under Y- $\Delta$  startup mode.
4. Power supply: 380V 3N-50Hz; allowable voltage fluctuation:  $\pm 10\%$ .
5. Standard water vessels pressure: 1.0 MPa.
6. Specification parameters are subject to change without prior notice, due to product improvement.

# Technical Parameter Correction Factor Diagram

Cooling capacity correction factor diagram of the water-cooled flooded screw chiller

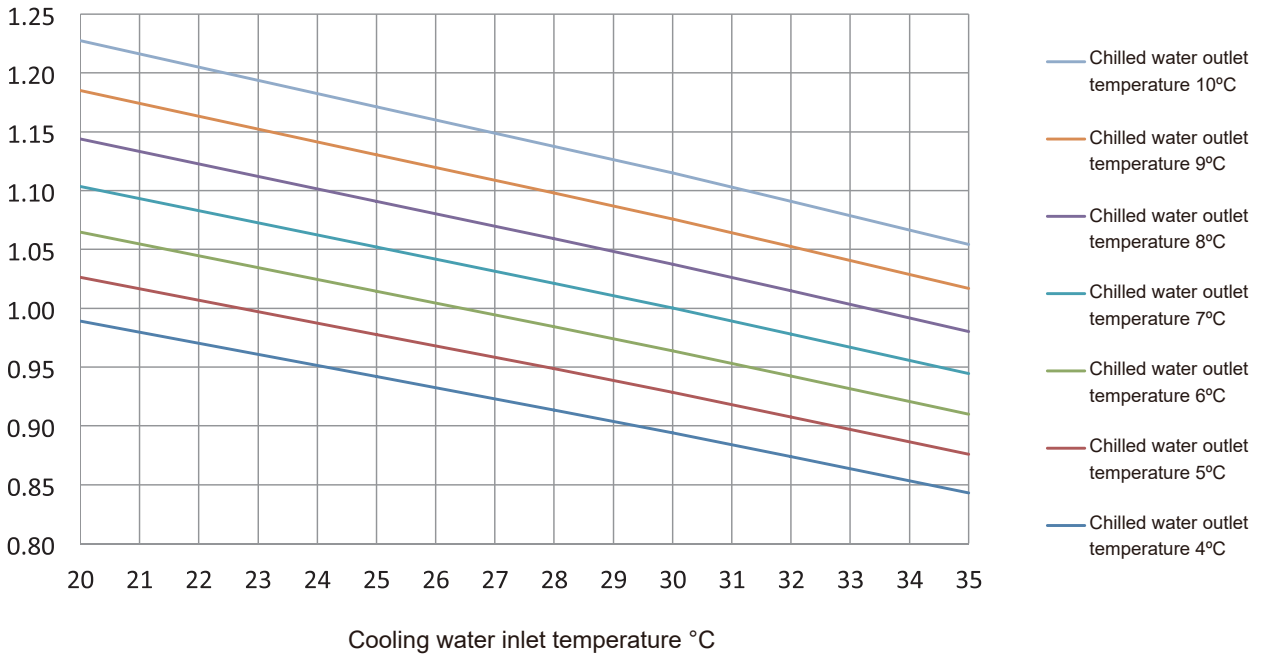

Input power correction factor diagram of the water-cooled flooded screw chiller

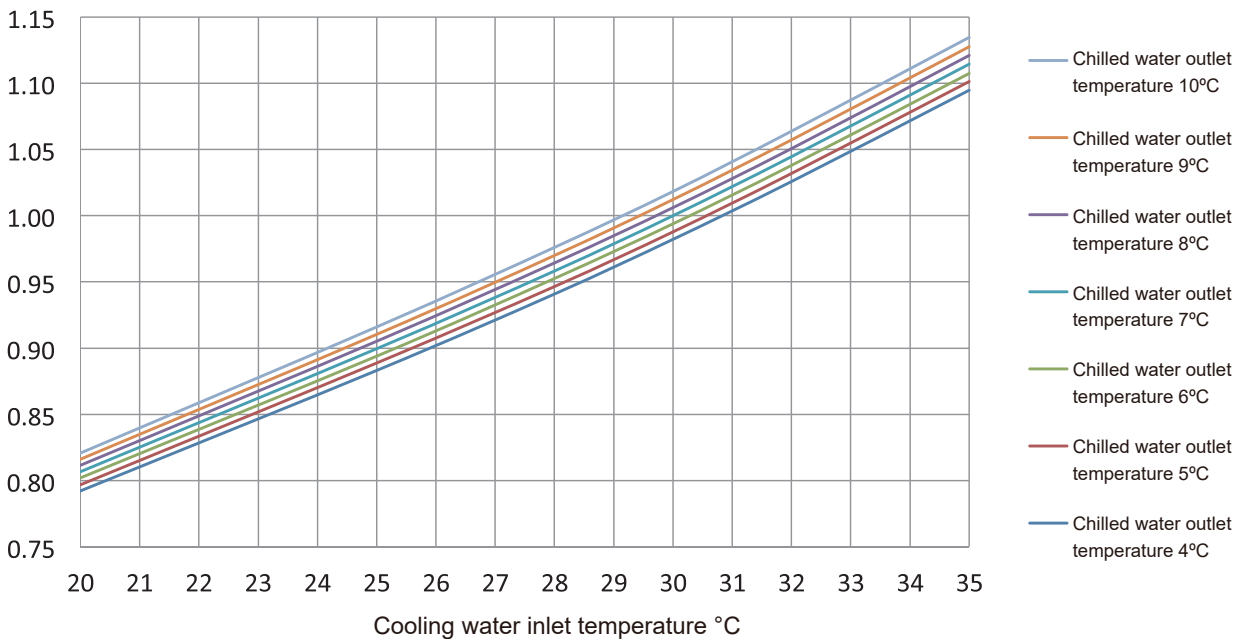

## Options

<b>1. Electric control</b>	
Circuit breaker, soft start, start by inverter, remote monitoring, remote operation screen, and PLC control (Siemens)	
<b>2. Vessels</b>	
Tube connection direction (Facing control cabinet)	Right
Water-side Pressure	1.6MPa, 2.0MPa
Connection Type	Flange connection
<b>3. Others</b>	
Damping device	Spring shock-absorbing cushions
Chiller insulation	40mm rubber and plastic insulation material
Chiller package	Ordinary wooden box, fumigated wooden box
Bottom channel steel	Yes

# Unit Dimensions

## —One Compressor high-efficiency series

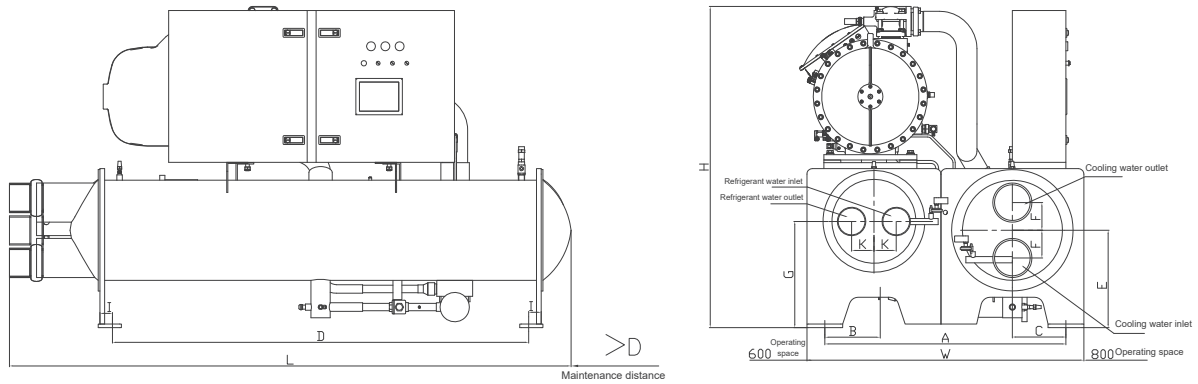

Model (TWSF-FC1)	Evaporator water inlet/outlet	Condenser water inlet/outlet	A	B	C	D	E	F	G	L	W	H	K	I
0110.1	DN150	DN150	1300	275	275	2330	495	125	595	3122	1500	1800	125	70
0135.1	DN150	DN150	1300	275	275	2330	495	125	595	3122	1500	1800	125	
0160.1	DN150	DN150	1300	275	275	2330	495	125	595	3122	1500	1800	125	
0175.1	DN150	DN150	1300	275	275	2330	495	125	595	3122	1500	1800	125	
0200.1	DN150	DN200	1350	275	300	2330	545	155	595	3144	1550	1850	125	
0220.1	DN150	DN200	1350	275	300	2330	545	155	595	3144	1550	1850	125	
0240.1	DN150	DN200	1350	275	300	2330	545	155	570	3144	1550	1850	130	
0265.1	DN150	DN200	1350	275	300	2330	545	155	570	3144	1550	1850	130	

★ **Note:**

1. The water inlet and outlet pipes of evaporator and condenser must be supported to avoid applying any external force to the unit.
2. The size of the equipment room area can guarantee repair and maintenance of the evaporator and condenser.

## —Double compressors high-efficiency series

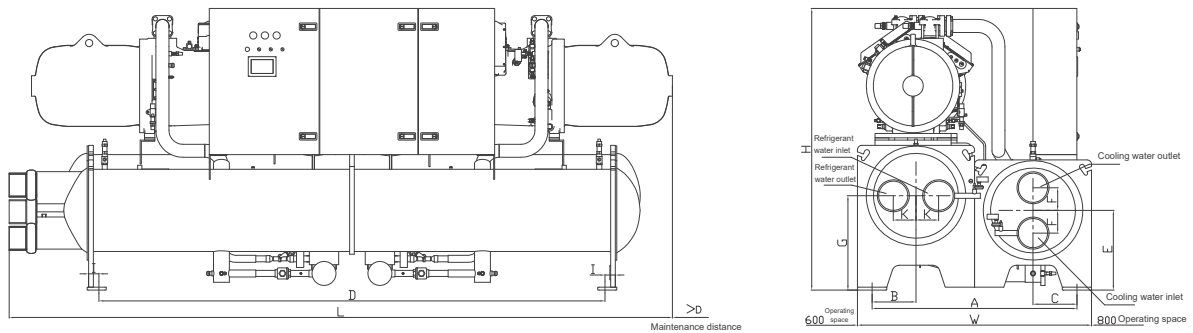

Model (TWSF-FC1)	Evaporator water inlet/outlet	Condenser water inlet/outlet	A	B	C	D	E	F	G	L	W	H	K	I
0280.2	DN200	DN200	1400	300	300	3460	545	155	645	4497	1600	1950	155	70
0300.2	DN200	DN200	1400	300	300	3460	545	155	645	4497	1600	1950	155	
0325.2	DN200	DN200	1400	300	300	3460	545	155	645	4497	1600	1950	155	
0350.2	DN200	DN200	1400	300	300	3460	545	155	645	4497	1600	1950	155	
0370.2	DN200	DN200	1600	350	350	3460	595	180	695	4540	1800	2050	180	
0390.2	DN200	DN200	1600	350	350	3460	595	180	695	4540	1800	2050	180	
0410.2	DN200	DN200	1600	350	350	3460	595	180	695	4540	1800	2050	180	
0430.2	DN200	DN200	1600	350	350	3460	595	180	695	4540	1800	2050	180	
0450.2	DN200	DN200	1600	350	350	3460	595	180	695	4540	1800	2050	180	
0465.2	DN200	DN200	1600	350	350	3460	595	180	695	4624	1800	2050	180	
0495.2	DN200	DN200	1600	350	350	3460	595	180	695	4624	1800	2050	180	
0510.2	DN200	DN200	1600	350	350	3460	595	180	695	4652	1800	2050	180	

★ **Note:**

1. The water inlet and outlet pipes of evaporator and condenser must be supported to avoid applying any external force to the unit.
2. The size of the equipment room area can guarantee repair and maintenance of the evaporator and condenser.

## —One Compressor super high-efficiency series

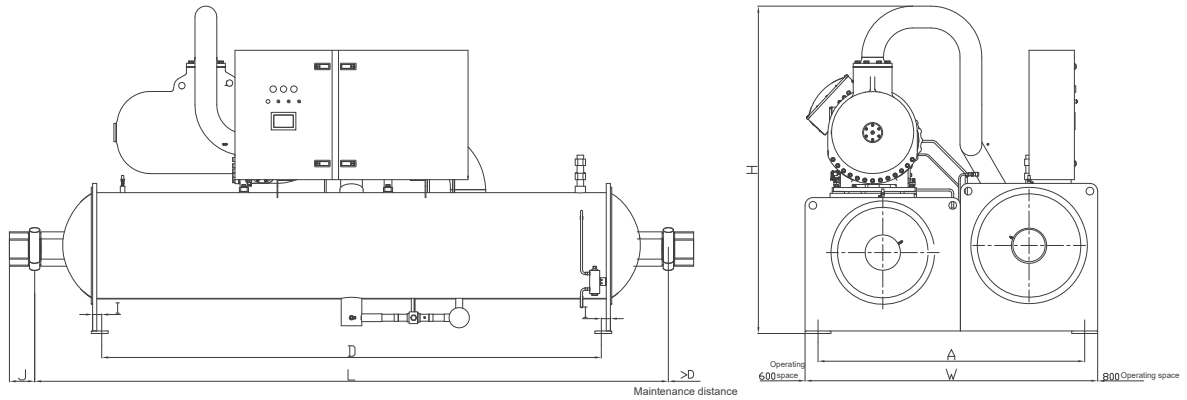

Model (TWSF-FC1)	Evaporator water inlet/ outlet	Condenser water inlet/ outlet	A	D	L	W	H	I	J
0430.1	DN200	DN250	2060	3460	4800	2260	2600	70	200
0450.1	DN200	DN250	2060	3460	4800	2260	2600		
0470.1	DN200	DN250	2060	3460	4800	2260	2600		

## —Double compressors super high-efficiency series

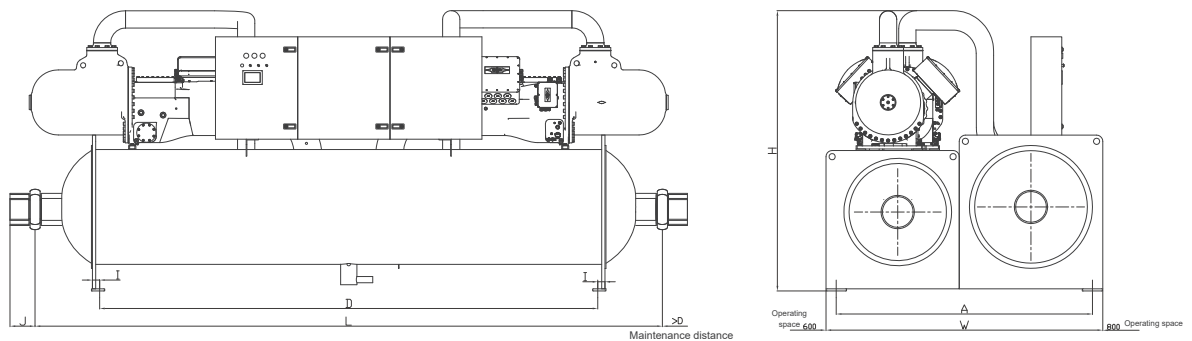

Model (TWSF-FC1)	Evaporator water inlet/ outlet	Condenser water inlet/ outlet	A	D	L	W	H	I	J
0850.2	DN250	DN300	2500	5360	6700	2700	2750	70	200
0900.2	DN250	DN300	2500	5360	6700	2700	2750		
0940.2	DN250	DN300	2500	5360	6700	2700	2750		

### ★ Note:

1. The water inlet and outlet pipes of evaporator and condenser must be supported to avoid applying any external force to the unit.
2. The size of the equipment room area can guarantee repair and maintenance of the evaporator and condenser.



# AIR-COOLED SCREW CHILLER



The TASD series air-cooled screw chiller adopts the modular design to provide cold water to air side products of central air conditioners. Selective cooling parts and control components provided by world-famous manufacturers, together with the most cutting-edge intelligent control system, contribute to the high efficiency, energy conservation, stability and reliability of this air-conditioning. The standard multi-unit control function supports the control over up to 8 units at the same time; and an optional build-in hydraulic module can be configured as required. The unit can also be connected to the building automation system (BAS) to easily meet various air-conditioning requirements in different places. The unit can be applied to various situations for comfortableness and arts and crafts, such as, hotel, hospital, office building, shopping mall, apartment, and factory.

## Nomenclature

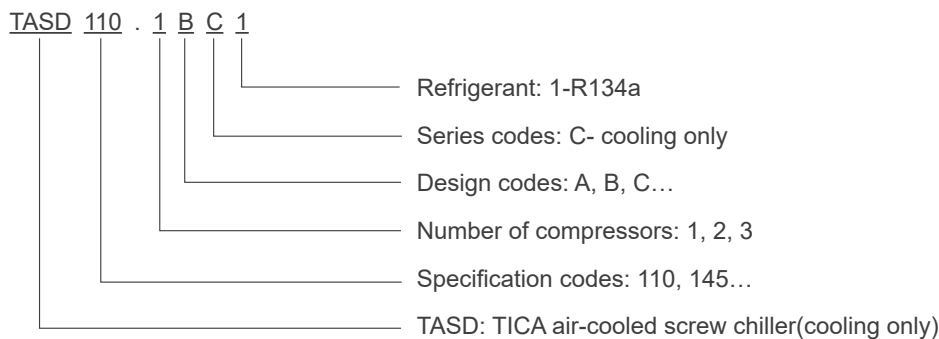

## Features

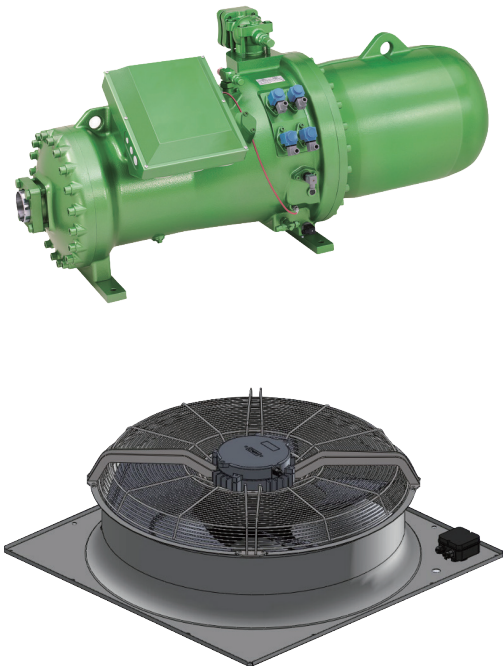

### Stable and reliable operation

- ◆ The unit compressor adopts the high-efficiency semi-hermetical twin-screw design. Therefore, it can be used without concern for refrigerant leakage, when compared to the hermetical compressor, it boasts easier maintenance and less pay for any repairs; and when compared to the single-screw compressor, it features fewer vulnerable parts, zero energy loss, and higher reliability.
- ◆ The compressor motor directly connects to the rotor with no gearbox involved, which avoids energy loss caused by gear transmission; moreover, fewer moving parts can ensure lower noise and a more reliable operation.
- ◆ The unit uses the stand-alone pass and in particular, the two stand-alone passes for twin-compressor units. In this way, the unit can guarantee reliable operations, and there is no requirement for the oil balance pipeline between units, ensuring better backup and substantially improving the unit reliability.
- ◆ The unit control system features high efficiency, reliability, and intelligence through constant optimization by engineers. All cooling parts and control components of the unit are provided by world-famous reliable suppliers to make the unit compact, highly efficient, energy saving, and reliable.
- ◆ The performance, reliability and structure of the unit are verified and optimized by the long-term simulation tests under various changing conditions and extreme conditions, as well as transportation experiment on actual tertiary roads.

### Modular design

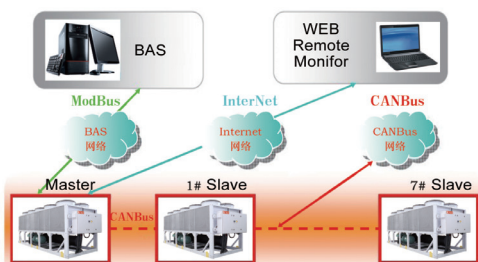

- ◆ The unit adopts the modular design. Each microcomputer controller of the unit reserves the interface for connecting the combined control module. Networking control between units can be implemented by cable connection and simple master-slave settings. A maximum of 8 main units can be controlled in a combined manner, which means that the unit capacity can be easily expanded to meet various air-conditioning requirements in different places.
- ◆ The main unit can be used to manage all modules in a centralized manner, select the number of modules, and monitor the operating data and status.
- ◆ Modules are independent of each other. A single failure of a module in a unit does not affect the operation of the other modules.
- ◆ The unit is provided with standard RS485 interface and supports the MODBUS-RTU protocol. It can implement centralized control and remote monitoring of the unit, and regulate other chiller auxiliaries as required by the BAS.

## Convenient installation



- ◆ The unit can be directly installed outdoors without the cooling tower. The compact structure of the unit takes small space and is cost-saving.
- ◆ The lifting lug design makes the hoisting process simple and safe.
- ◆ The water pipe of the water-side heat exchanger has been equipped with the water flow switch and is ready to use, which saves the on-site installation time.
- ◆ Inlet and outlet pipes are clamped, which makes the on-site installation easier.
- ◆ The unit comes with the startup cabinet and control cabinet and has been filled with refrigerant and refrigeration oil before delivery. Only the water pipe and power supply need to be connected upon installation on site. The unit can be put into use after the initial on-site commissioning by the after-service personnel of TICA.
- ◆ The built-in hydraulic module of the unit is optional. This module integrates all necessary hydraulic components such as the water pump, filter, expansion tank, flow switch, safety valve, pressure gauge, and drainage valve. Customers can debug the running after connecting the water pipes at ends.

## Electronic expansion valve



- ◆ The unit uses the world's most advanced electronic expansion valve, which ensures excellent performance both under full load or partial load and higher control accuracy.
- ◆ When compared with the thermal expansion valve, electronic expansion valve reacts more quickly when the unit is partly loaded. In addition, the evaporator can be fully used in any condition, which ensures more adequate and higher efficient heat exchange.

## High-efficiency compressor

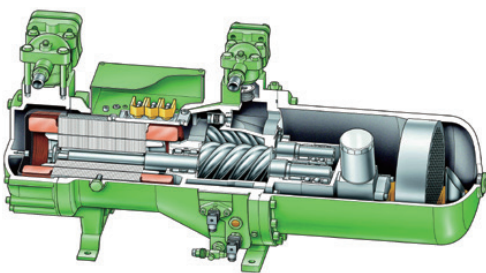

- ◆ The highly efficient semi-hermetical twin-screw compressor adopts the world-class latest generation 5:6 patented asymmetric tooth-type rotor to greatly improve the adiabatic efficiency. This type of high-efficiency motor with large capacity can significantly enhance the energy efficiency.
- ◆ The compressor motor directly connects to the rotor with no gearbox involved, which avoids energy loss caused by gear transmission; moreover, fewer moving parts can ensure lower noise and a more reliable operation.
- ◆ The high-precision filter screen built in the compressor increases the oil separation efficiency up to 99.5%.
- ◆ The unit adopts the semi-enclosed twin-screw compressor and air suction cooling motor to ensure that the motor is fully cooled.
- ◆ The compressor adopts the slide valve for adjustment. A single compressor can precisely match 25% – 100% load changes, and dual-compressor up to 12.5% – 100% load changes, which reduces operating expenditure to the greatest extent.



## Low-noise operation

- ◆ The unit adopts the low-noise type outer rotor axial flow fan with long type air duct for diversion to effectively reduce the airflow noise. Before delivery, the fan has undergone strict tests for static and dynamic equilibrium to ensure stable and low-noise operation.
- ◆ The silencer built in the compressor reduces noise effectively.
- ◆ The compressor uses the precision machined rotor and the surface of the rotor is hardened by laser. The correction of static and dynamic equilibrium can minimize the vibration.
- ◆ The compressor feet are equipped with shock pads to reduce unit vibration and substantially lower the unit noise.

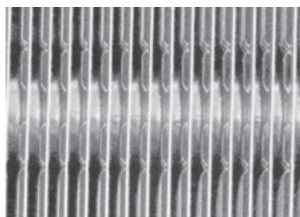
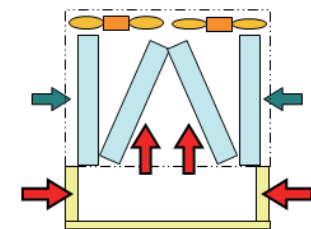
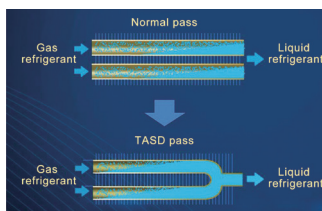

## High-efficiency heat exchanger

- ◆ The patented counter-current water-side heat exchanger, combined with the inner-threaded efficient heat exchange pipe, can increase heat exchange efficiency by 20% to 30%.
- ◆ The wind-side heat exchanger adopts a unique process design to ensure that the refrigerant is in the best flow rate in any condition. In this way, the refrigerant pressure in the wind-side heat exchange copper pipe can be reduced to a minimum, which effectively decreases the power consumption of the compressor and improves the energy efficiency of the unit.
- ◆ The use of inverted “M” type heat exchanger reduces ventilation resistance, improves air flow velocity distribution, and increases heat exchange efficiency.
- ◆ The use of large air volume silent fan increases the air flow through the tube fins, which improves the heat exchange efficiency of the wind-side heat exchanger.
- ◆ The graded control of the unit fan effectively reduces the fan power consumption of the unit in the transitional ambient temperature.
- ◆ The use of new open-window aluminium fin greatly enhances the gas turbulence of the wind-side heat exchange tube and the surface of the fin. In this way, the heat exchange efficiency is increased by about 8%.

## Unit microcomputer control center

The industrial-level microcomputer controller, together with the LCD touch screen, constitutes the control unit of the unit. While TICA's unique self-control technology and up-to-edge control technology in the world create powerful control functions of our controller.

The leading intelligent control program ensures accurate management of water temperature under any condition and guarantees energy-saving, safe, and stable operation of the unit by automatic control. Meanwhile, the advanced pre-control function enables measures to be taken timely before actual failure occurs to avoid frequent shutdown of the unit.

The unit supports the compiling of weekly operating schedules to implement comprehensive automatic start and stop control of the unit, which truly implements unattended and automatic operation.



### Main functions:

Local and remote automatic control  
 Start and stop control of the unit  
 Real-time display of the operating status and parameters  
 Display and settings of control parameters  
 Self-test upon unit startup  
 Adjustment and control of the energy  
 Control of the balanced operation of the compressor  
 Control to prevent frequent startup of the compressor  
 Graded energy-saving control of the fan  
 Water pump interlock control  
 Multi-unit control  
 Real-time displaying operation permission grading function  
 Automatic shutdown upon alarm and failure display function  
 Historical fault memory function  
 RS485 communication interface (communication function)

### Protection functions:

Power overvoltage and under-voltage protection  
 Protection of power supply default phase, reverse phase, and unbalanced phase  
 Compressor oil level protection  
 Compressor motor overheat protection  
 Compressor motor overload protection  
 Compressor overload protection  
 Compressor start failure protection  
 Protection of over high condensation pressure (exhaust)  
 Protection of over low evaporation pressure (suction)  
 Protection of air suction/exhaust pressure difference  
 System pressure warning protection  
 Protection of over low cooling outlet water temperature  
 Water flow switch protection  
 Protection of over high air exhaust temperature  
 Communication failure protection  
 EVD electronic expansion valve protection

## Reliable performance



- ◆ TICA designers conduct optimal design for critical components and system pipelines of the chiller on the basis of existing theories and in combination with internationally advanced design concepts and always put the stability of the chiller in the first place.
- ◆ The chiller adopts compressor of international famous brand with high stability.
- ◆ Original control by electronic expansion valve effectively solves problems of carrying liquid, throwing oil and system oscillation, etc. during defrosting and enables stable operation of the chiller.
- ◆ Balanced design of high precision for distribution pipe of refrigerant in heat exchanger on air side of the chiller guarantees uniform distribution of refrigerant in heat exchanger on air side, enhances heating capacity and improves frosting condition.
- ◆ External oil cooler controls oil temperature of compressor and enables more stable and reliable heating operation of the chiller at low temperature.
- ◆ Long-term simulation tests: including tests for various variable working conditions, extreme working conditions, defrosting of heat pump and practical tertiary highway transportation, etc. to verify and optimize performance, reliability and structure of the chiller.

# Technical Specifications

## TASD-AC1(R134a) - Cooling Only

Unit Model TASD-AC1		110.1	145.1	170.1	210.1	230.2	260.2	285.2	345.2	405.2	
Capacity	kW	385	505	601	730	808	909	1001	1210	1425	
Power Input	kW	123	159	189	233	254	285	319	379	464	
Rated Current	A	219	288	341	419	479	507	578	690	840	
Max.Starter Current	A	615	845	845	965	1102	1264	1358	1358	1486	
Max.Running Current	A	419	513	523	521	900	932	1026	1026	1042	
Power Supply		380-415V3N- 50Hz									
Evaporator	Type	Tube-and-shell evaporator									
	Water flow	m <sup>3</sup> /h	66	87	103	126	139	156	172	208	245
	Inlet/Outlet DN	DN	125	125	125	150	150	150	150	200	200
	Pressure Drop	kPa	40	53	56	57	68	72	73	70	68
	Water-side Pressure	MPa	1.0								
Connection Type		victaulic coupling									
Compressor	Type	Semi-hermetical screw compressor									
	Energy control	25%-100% four step control				12.5%-100% eight step control					
	Starter Mode	Y-△									
Fan	Air Flow	m <sup>3</sup> /h	150000	200000	250000	250000	350000	350000	400000	400000	500000
	Quantity	Piece	6	8	10	10	14	14	16	16	20
Refrigerant	Type	R134a									
	System Quantity	1				2					
Dimension	Length	mm	3787	4792	5797	5797	8707	8707	9712	9712	11700
	Width	mm	2250								
	Height	mm	2420				2480				
Hydraulic Module (Option)	Built-in Hydraulic Module (Option)	Water pump, expansion tank, filter, safety valve, pressure gauge, butterfly valve etc.									
	Water Pump Type	Centrifugal single pump or twin pump (option)									
Net Weight	kg	4350	4690	5500	6050	7850	7980	9200	9550	11800	
Running Weight	kg	4550	4910	5750	6340	8190	8340	9590	9980	12400	

★ **Note:**

1. Nominal cooling conditions: Chilled water inlet/outlet temperature 12/7°C , Ambient temperature 35°C;
2. Power supply fluctuation range: ±10%.
3. If you need low ambient temperature cooling function, please contact with sales representatives.
4. When choose built-in hydraulic kit, please remark pump lifting.
5. Due to possible product improvement, TICA reserves the right to make changes in design and construction at any time without notice.
6. For more details, please contact with TICA headquarter.

## TASD-BC1(R134a) - Cooling Only

Unit Model TASD-BC1		110.1	145.1	180.1	210.1	255.2	290.2	325.2	360.2	390.2	420.2	
Modular Model		-	-	-	-	110+145	145+145	145+180	180+180	180+210	210+210	
Capacity	kW	385	505	642	741	890	1010	1147	1283	1383	1482	
Power Input	kW	124	160	201	242	284	319	361	402	443	484	
Rated Current	A	216	278	349	421	493	555	627	699	770	842	
Max.Starter Current	A	615	683	845	965	1102	1164	1326	1368	1488	1486	
Max.Running Current	A	419	481	523	521	900	962	1004	1046	1044	1042	
Power Supply		380V 3N ~ 50Hz										
Evaporator	Type	Tube-and-shell evaporator										
	Water Flow	m <sup>3</sup> /h	66	87	110	127	153	174	197	221	238	255
	Inlet/Outlet DN	DN	150	150	150	150	150+150	150+150	150+150	150+150	150+150	150+150
	Pressure Drop	kPa	62	64	58	79	64	64	64	58	79	79
	Water-side Pressure	MPa	1.0									
Connection Type		victaulic coupling										
Compressor	Type	Semi-hermetical Screw Compressor										
	Energy control	25%-100% Four-grade Regulation					12.5%-100% Eight-grade Regulation					
	Starter Type	Y-△										
Fan	Air Flow	m <sup>3</sup> /h	132000	176000	220000	250000	308000	352000	396000	440000	470000	500000
	Quantity	Set	6	8	10	10	14	16	18	20	20	20
Refrigerant	Type	R134a										
	System Quantity	1					2					
	Charge Amount	kg	86	100	115	150	186	200	215	230	265	300
Dimensions	Length	mm	3787	4792	5797	5797	9579	10584	11589	12594	12594	12594
	Width	mm	2250									
	Height	mm	2470									
Shipping Weight	kg	4300	4650	5450	6000	9000	9350	10150	10950	11500	12050	
Operating Weight	kg	4500	4880	5700	6300	9430	9810	10630	11450	12050	12650	

★ **Note:**

1. Cooling conditions: water inlet/outlet temperature 12/7°C, ambient temperature 35°C;
2. Allowable voltage fluctuation: ±10%;
3. 260RT and later models adopt two modular units, which are transported separately and assembled in parallel on site. The water system pipes of the two units are connected by the client.
4. The specifications are subject to change due to product improvement without prior notice.

# Technical Parameter Correction Factor Diagram

## Cooling capacity correction factor diagram

Water Outlet Temperature °C	15		20		25		30		35		40		45		50	
	Cooling Capacity kW	Power kW	Cooling Capacity kW	Power kW	Cooling Capacity kW	Power kW	Cooling Capacity kW	Power kW	Cooling Capacity kW	Power kW	Cooling Capacity kW	Power kW	Power kW	Power kW	Power kW	Power kW
5	1.16	0.75	1.11	0.79	1.06	0.83	1.00	0.89	0.94	0.97	0.88	1.05	0.80	1.17	0.74	1.28
7	1.23	0.76	1.18	0.80	1.12	0.86	1.06	0.92	1.00	1.00	0.94	1.08	0.86	1.21	0.79	1.32
8	1.27	0.76	1.22	0.81	1.16	0.87	1.10	0.93	1.03	1.02	0.96	1.10	0.89	1.22	0.82	1.34
10	1.34	0.80	1.29	0.84	1.23	0.89	1.16	0.96	1.09	1.05	1.02	1.14	0.95	1.26	0.87	1.38
12	1.42	0.82	1.36	0.87	1.30	0.92	1.23	1.00	1.16	1.08	1.08	1.17	1.02	1.30	0.93	1.42
15	1.54	0.85	1.48	0.91	1.41	0.97	1.33	1.04	1.25	1.13	1.17	1.24	1.12	1.37	1.02	1.49

## Unit operation condition range

Cooling

Shell and Tube Heat Exchanger(Evaporator)	Minmum Temperature	Maximum Temperature
Inlet Water Temperature(Starting)	—	35
Outlet Water Temperature(Operating)	5	15
Fin Heat Exchanger (Condenser)	Minmum Temperature	Maximum Temperature
Inlet Air Temperature	15	43°C (TASD-AC1) 50°C (TASD-BC1)

★ **Note:**

If the actual application condition is beyond the above data, please contact with TICA.

## Unit water pressure drop diagram

### TASD-AC1

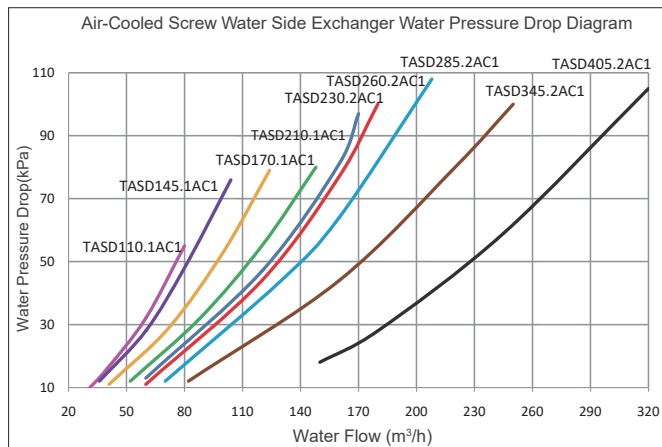

### TASD-BC1

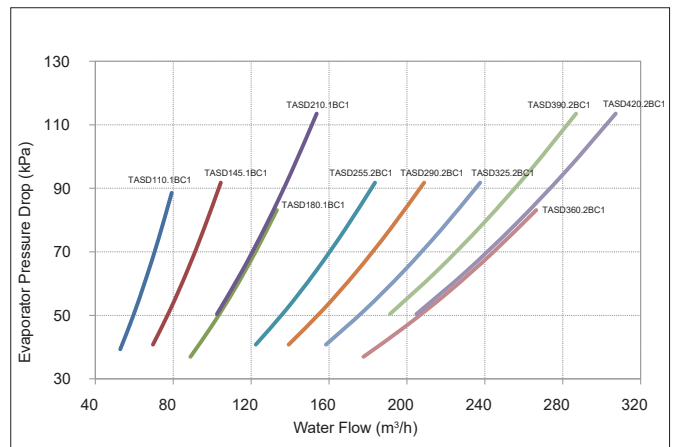



## Options

<b>1. Electric control</b>	
Soft start, Start by inverter, PLC control (Siemens), Year-round cooling unit(-5°C), Hydraulic KIT	
<b>2. Vessels</b>	
Tube connection direction (Facing control cabinet)	Left
Water-side Pressure	1.6MPa, 2.0MPa
Connection Type	Flange connection
Condenser	Protection screen
Condenser	Finned anti-corrosion
<b>3. Others</b>	
Damping device	spring shock absorber.
Chiller insulation	40mm rubber and plastic insulation material
Compressor	Compressor noise enclosure
Chiller package	Ordinary wooden box, fumigated wooden box

# Unit Dimensions

## TASD110.1AC1

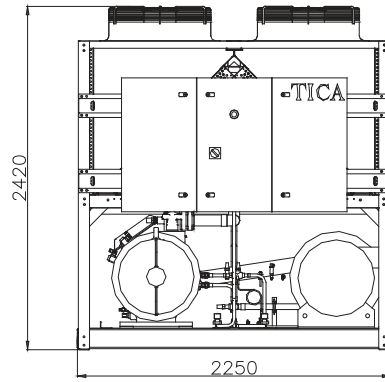
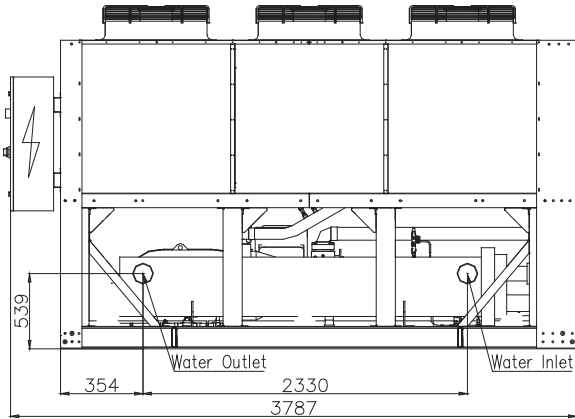

Base vibration absorption installation diagram

6- $\phi$ 14 vibration absorption installation hole

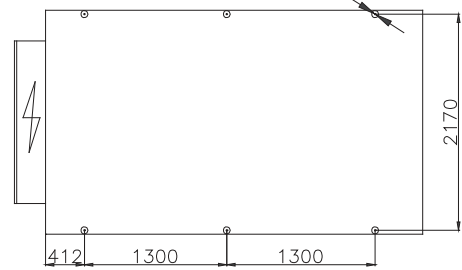

## TASD145.1AC1

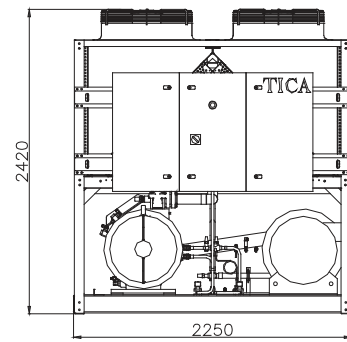
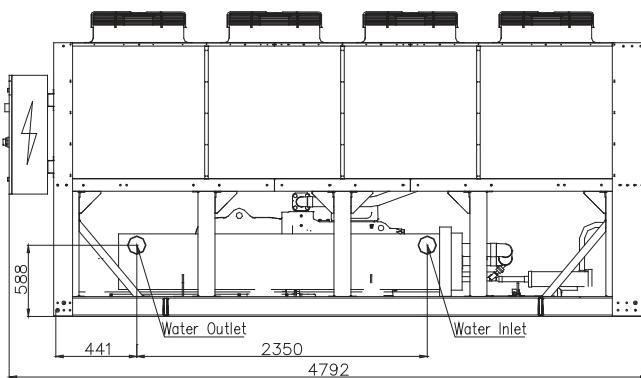

Base vibration absorption installation diagram

8- $\phi$ 14 vibration absorption installation hole

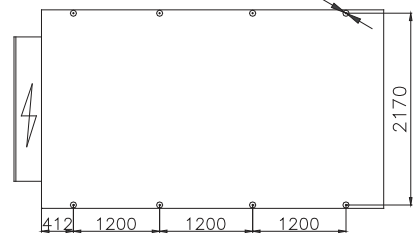

### TASD170.1AC1

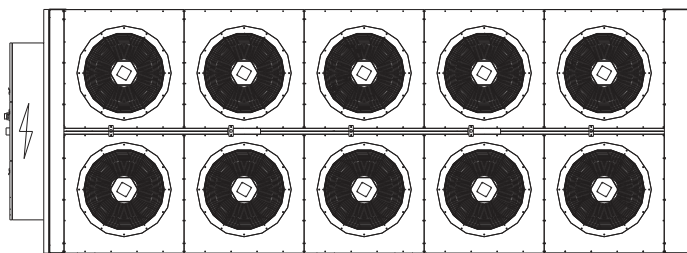
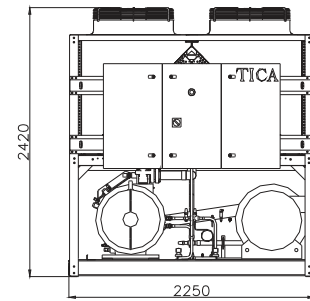
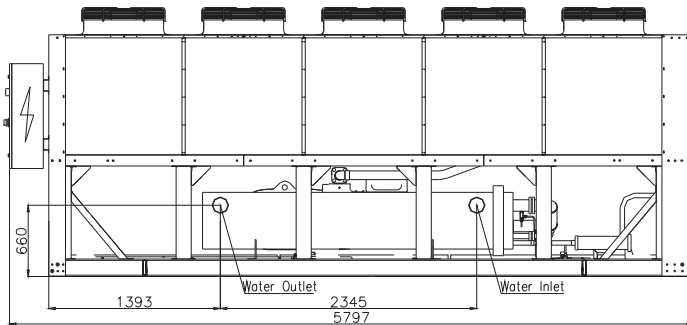

Base vibration absorption installation diagram

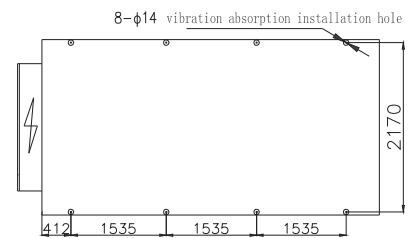

### TASD210.1AC1

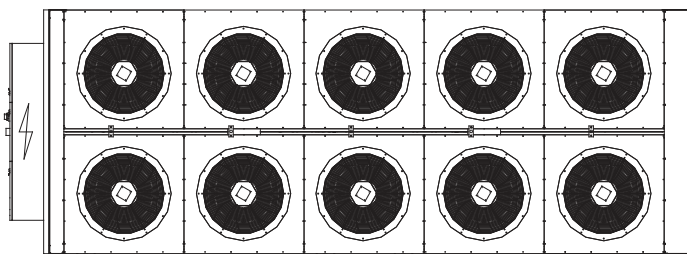
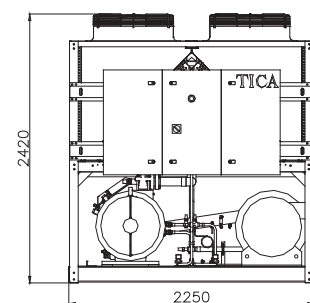
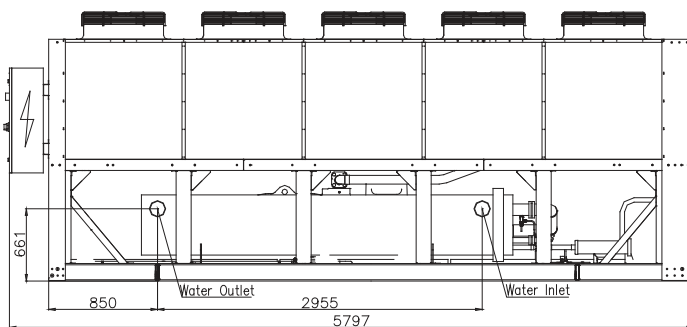

Base vibration absorption installation diagram

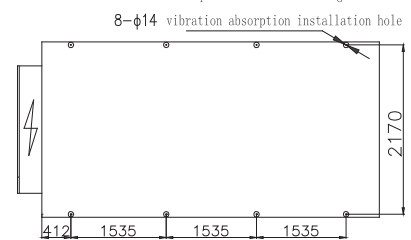

### TASD 230/260.2 AC1

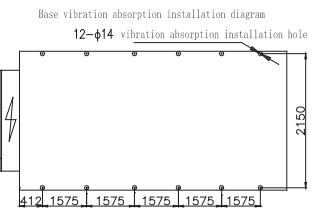
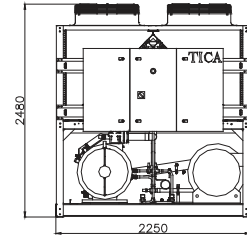
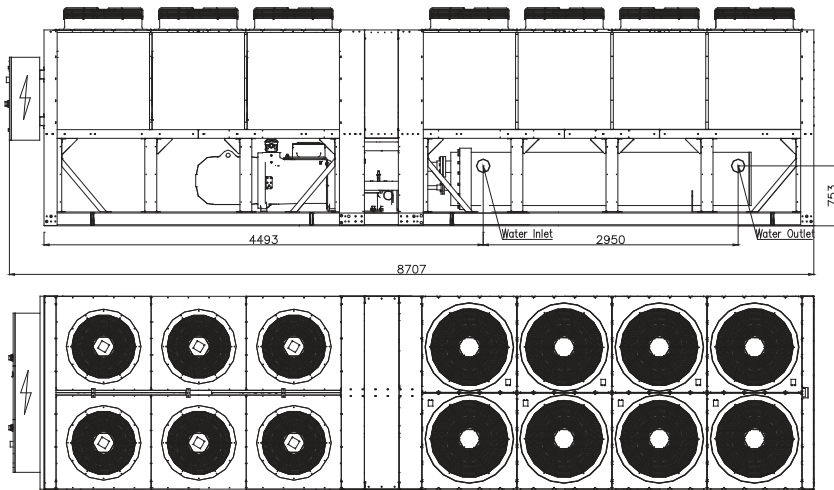

### TASD 285.2 AC1

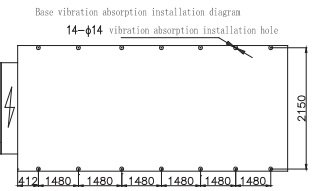
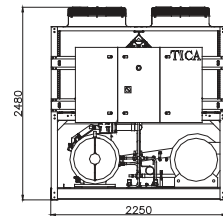
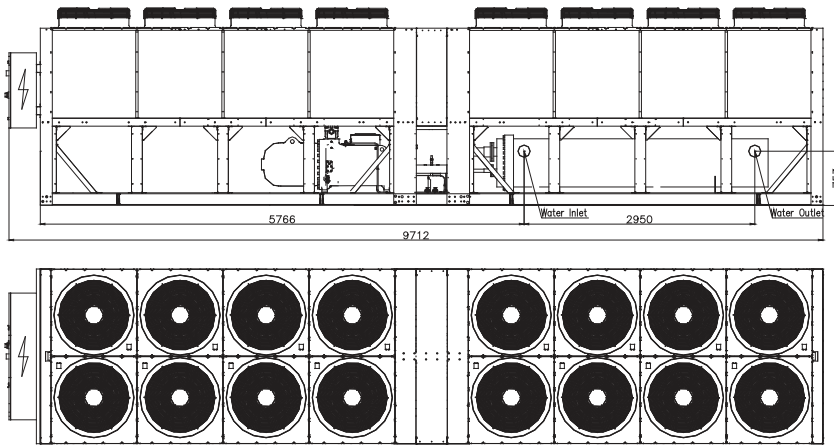

### TASD 345.2 AC1

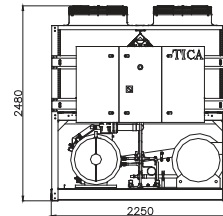
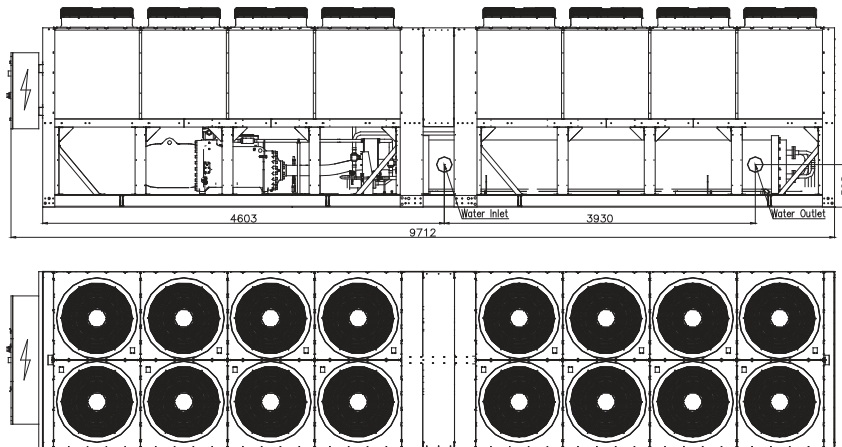

Base vibration absorption installation diagram  
14-φ14 vibration absorption installation hole

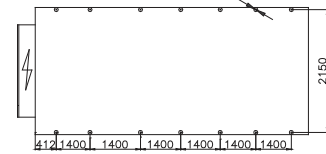

### TASD 405.2 AC1

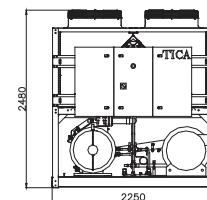
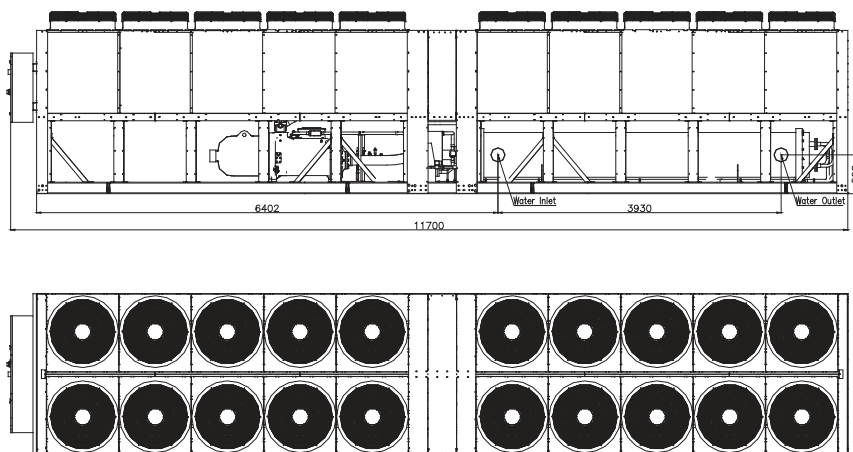

Base vibration absorption installation diagram  
16-φ14 vibration absorption installation hole

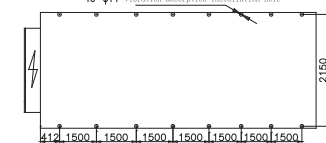

## TASD110/145/180/210BC1

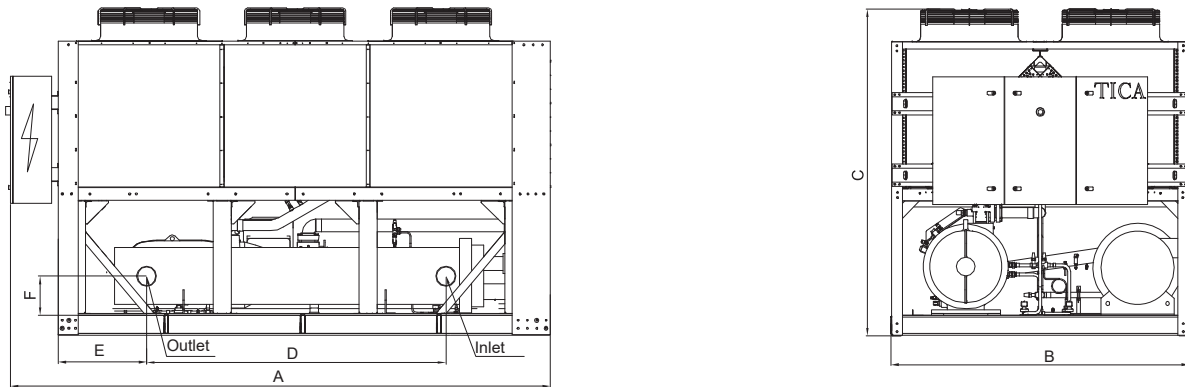

Model	External Unit Dimensions (mm)					
	A	B	C	D	E	F
TASD110.1BC1	3787	2250	2470	2300	369	606
TASD145.1BC1	4792	2250	2470	2300	611	606
TASD180.1BC1	5797	2250	2470	2300	1440	606
TASD210.1BC1	5797	2250	2470	2950	870	606

## TASD255/290/325/360/390/420BC1

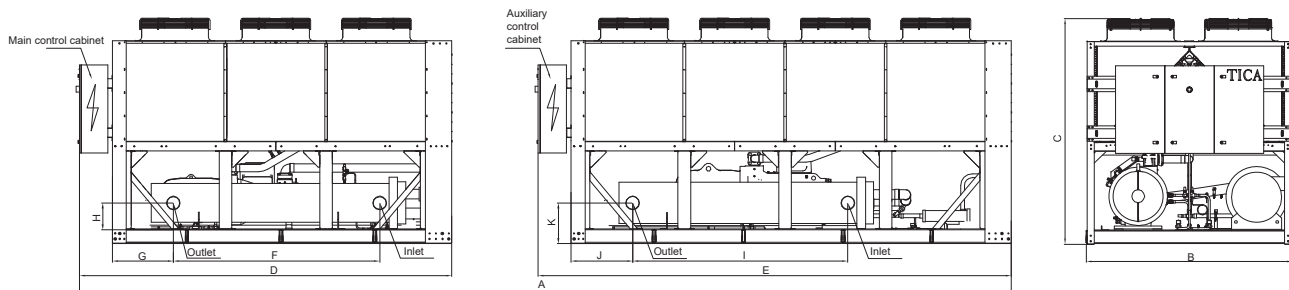

Model	External Unit Dimensions (mm)										
	A	B	C	D	E	F	G	H	I	J	K
TASD255.2BC1	9579	2250	2470	3787	4792	2300	369	606	2300	611	606
TASD290.2BC1	10584	2250	2470	4792	4792	2300	611	606	2300	611	606
TASD325.2BC1	11589	2250	2470	4792	5797	2300	611	606	2300	1440	606
TASD360.2BC1	12594	2250	2470	5797	5797	2300	1440	606	2300	1440	606
TASD390.2BC1	12594	2250	2470	5797	5797	2300	1440	606	2950	870	606
TASD420.2BC1	12594	2250	2470	5797	5797	2950	870	606	2950	870	606



Follow the Account of TICA to see more solutions

---

NANJING TICA CLIMATE SOLUTIONS CO.,LTD.  
Add: No.6 Hengye Road, Development Zone, Nanjing, China  
Post: 210046  
Tel: +86-25-85326977  
E-mail: [global@ticachina.com](mailto:global@ticachina.com)  
Website: [www.global.tica.com](http://www.global.tica.com)

---

DISCLAIMER NOTE: Data provided herein are not binding and might change without prior notice.